



DIATRIM

Leading manufacturer of diamond cutting tools since 1981

Product Catalog



Air Tools • Blades • Holesaws • Special Cutters

Increasing your productivity is our priority!

In 1971 we began selling diamond tools and air saws to the FRP industry. Since that time our goal has always been to help our customers find easier ways to trim and shape their products. This striving to offer better tools for the industry convinced us to begin manufacturing our own diamond cutting tools in 1981, so that we could supply exactly what the "guys in the shop" needed.

Close to 40 years later, Diatrim's approach focuses on the same principles:

- Stay close to the industry to better feel its needs
- Constantly work to meet our clients' needs
- Use acquired experience to create high quality tools

We are committed to providing high quality products that will increase productivity, in getting the job done quickly and efficiently.

Diatrim team

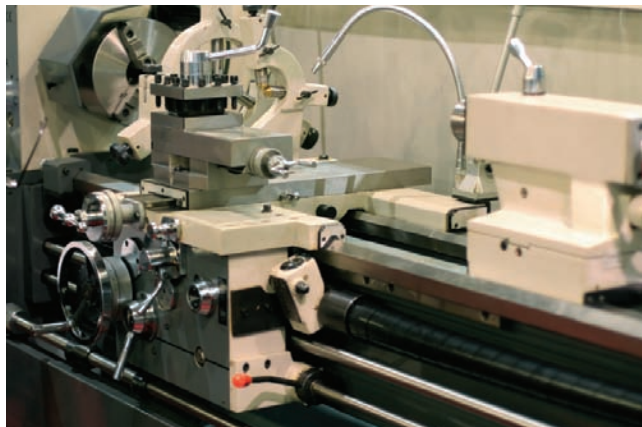

AIR TOOLS

Our pneumatic tools use heavy duty high quality motors that meet the highest standards for fast and ongoing production runs in manufacturing plants. These tools come with dust extractor guards.

TRIMMERS



3" trimmer
Item # 10-3

These light, powerful air saws are recommended for trimming smaller, thinner parts and are used by companies which are restricted to using smaller air compressors. The 3" model offers the dust extractor guard feature.



4" heavy duty trimmer
Item # 10-4

This powerful dependable air saw has been designed for fast production trimming of FRP parts up to 1" thick. Over the past 25 years, this saw has become the most widely used hand held air saw in the industry. Comes with a blade and a dust extractor guard. Open guard available upon request.



5" heavy duty trimmer
Item # 10-5

Our second most popular trimmer ! Same powerful motor used on our 4" trimmer. Includes a 5" side spoked blade and a dust extractor guard.

AIR TOOLS

TRIMMERS - Continued



6" Excalibur trimmer
Item # 10-6x

Our larger 6" Excalibur trimmer was designed for trimming FRP parts up to 1 5/8" of thickness. Comes with a Superspeed 1 blade and a dust extractor guard.



6 1/2" Excalibur trimmer
Item # 10-65x

Our larger 6 1/2" Excalibur trimmer was designed for trimming FRP parts up to 2" of thickness. Comes with a Superspeed 1 blade and a dust extractor guard.



8" heavy duty trimmer
Item # 10-8

Brand new!

This hand held trimmer was designed to cut FRP laminates up to 2,5" of thickness. Model sold with a Superspeed 1 blade and a dust extractor guard.

AIR TOOLS

TRIMMERS - Continued



10" heavy duty trimmer
Item # 10-10

Brand new!

This hand held trimmer was designed to cut FRP laminates up to 3,5" of thickness. Model sold with a Superspeed 1 blade and a dust extractor guard.

TECHNICAL SPECIFICATIONS - TRIMMERS

Code	Description	Blade			Cutting Depth	Air consumption	Speed RPM	Weight lbs
		Arbor	Diameter	Thickness				
10-3	3" trimmer	1 / 2	3 "	1/16 - 3/32	1 / 2"	19 cfm @ 90psi	12,000	3 lbs
10-4	4" trimmer	3 / 4	4 "	1/16 - 3/32	1"	23 cfm @ 80psi	12,700	4,5 lbs
10-5	5" trimmer	3 / 4	5 "	1/16 - 3/32	1 1/2"	23 cfm @ 80psi	12,700	5 lbs
10-6	6" trimmer	7 / 8	6 "	3/32	1 5/8"	44 cfm @ 90psi	12,000	7,5 lbs
10-65	6,5" trimmer	7 / 8	6,5 "	3/32	2"	44 cfm @ 90psi	12,000	7,5 lbs
10-8	8" trimmer	7 / 8	8 "	3/32 - 1/8	2 1/2"	49 cfm @ 85 psi		11 lbs
10-10	10" trimmer	7 / 8	10 "	3/32 - 1/8	3 1/2"	49 cfm @ 85 psi		12 lbs

ROUTER



High speed router
Item # 30-SE50

50 000 RPM high speed router with a 1/4" collet chuck. Each unit is fitted with a dust extraction cowl for jig following. 1/4" diamond coated router bit included. Excellent routing up to 1/4" thick laminate.

TECHNICAL SPECIFICATIONS - ROUTER

Code	Description	Collet chuck	Air consumption	Speed RPM	Weight lbs
30-SE50	High speed router	1 / 4"	12 cfm @ 90psi	50,000	2,25 lbs

AIR TOOLS

SANDER AND PLANER



4" sander
Item # 40-DS45

This unique 4" diamond disc sander allows operator to grind/sand a flat FRP part and pick up over 95 % of the dust created when attached to a dust extraction system. Cutter depth can be adjusted from 0 to 1/8". Cutter 75-DS4 sold separately.



2 1/4" planer
Item # 40-DP35

Our diamond planing tool has an adjustable nylon face plate which allows operator to plane / grind an area 2 1/4" wide and 1/32" to 1/8" deep in a single pass. Unit comes equipped with a dust extractor guard. Cutter 45-DP214 sold separately.

TECHNICAL SPECIFICATIONS -SANDER AND PLANER

Code	Description	Diameter	Cutting depth	Width	Air consumption	Speed RPM	Weight lbs
40-DS45	4" disc sander	4 "	0 to 1/8 "	4 "	23 cfm @ 80psi	12,700	6 lbs
40-DP35	2 1/4" planer	n/a	1/32 " to 1/8"	2 1/4"	23 cfm @ 80psi	12,700	6 lbs

AIR TOOLS

FLANGE TRIMMER



Flange trimmer Item # 20-FT25

This flange trimmer has been designed to trim flanges at production speed. Our adjustable nylon guide base can be set to various flange widths. Possibility of trimming up to 4" wide. All blade diameters are 3 1/2". For blade choices, refer to table. Blades are sold separately.

TECHNICAL SPECIFICATIONS - FLANGE TRIMMER

Code	Description	Blade diameter	Flange width	Air consumption	Speed RPM	Weight lbs
20-FT25	Flange trimmer	3,5"	1/2 to 4"	23 cfm @ 80psi	12,700	5 lbs

Code	Description	Flange width	
		Min	Max
53-FT351	Spindle saw for 20-FT25	1/2"	2 1/8"
53-FT352	Spindle saw for 20-FT25	1 1/2"	3"
53-FT353	Spindle saw for 20-FT25	3"	4"

BACKFACERS

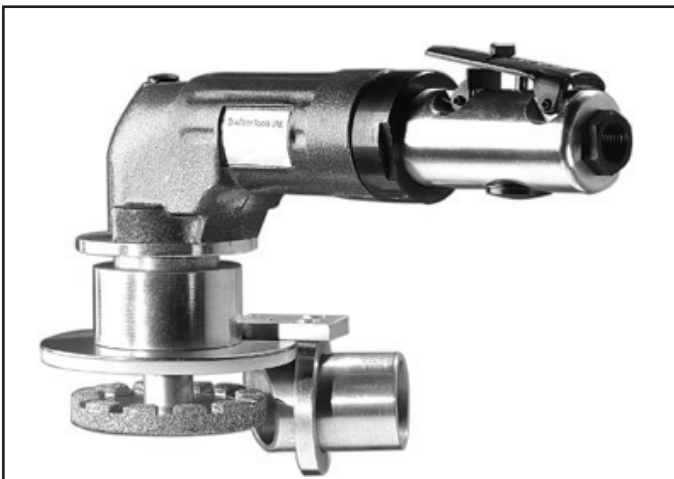

Backfacer - Flat parts Item # 20-BF15

This heavy duty backfacer will machine accurate thicknesses in flat parts. Adjustable nylon back plate will accommodate up to 3/4" thick laminate. Width of cut determined by diameter of backfacing cutter. Cutters sold separately.

AIR TOOLS

BACKFACERS - Continued



Backfacer - Curved of flat parts Item # 20-BF10

This powerful unit allows operator to machine an accurate thickness in flat or curved FRP parts. Adjustable rollers will accommodate up to 3/4" thick laminates. Width of cut determined by length of router used. Standard diamond routers are available in 1 1/4", 1 1/2", 2" and 2 1/2" lengths. Routers sold separately. Unit comes equipped with dust extractor guard with 1 1/2" diameter dust pipe.

TECHNICAL SPECIFICATIONS - BACKFACERS

Code	Description	Cutting width		Air consumption	Speed RPM	Weight lbs
		Min	Max			
BF-15	Flat parts backfacer	5/16"	1 9-16"	23 cfm @ 80psi	12,700	4,5 lbs
BF-10	Curved parts backfacer	1 1/4"	2 1/2"	23 cfm @ 80psi	12,700	4,5 lbs

CUTTERS FOR BF-15

Code	Cutter Diameter	Width of cut
70-BF112	1 1/2"	5/16"
70-BF2	2"	9/16"
70-BF212	2 1/2"	13/16"
70-BF3	3"	1 1/16"
70-BF4	4"	1 9/16"

ROUTERS BF-10

Code	Width of cut
70-2232	1 1/4"
70-2238	1 1/2"
70-2250	2"
70-2265	2 1/2"

BLADES

All diamond blades should be operated at speeds between 5 000 and 10 000 feet per minute. Blades will come with standard arbor size unless otherwise specified at time of order. Special sizes available upon request.

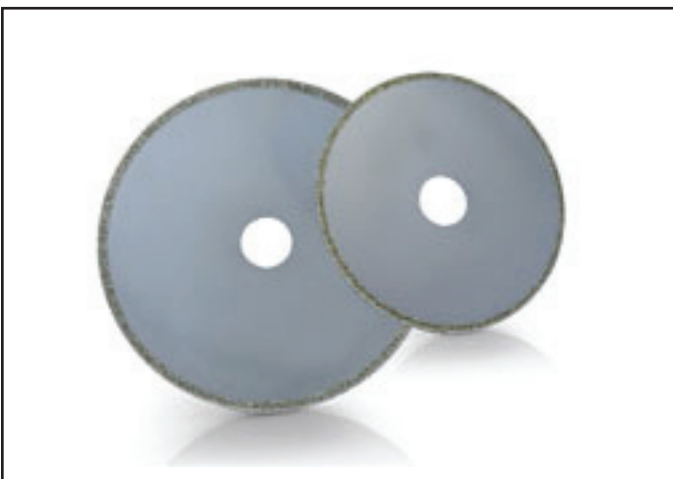

Continuous rim blade

Continuous rim blades are the most widely used for general purpose cutting. Width of diamond coating: 1/8"

BLADES - Continued

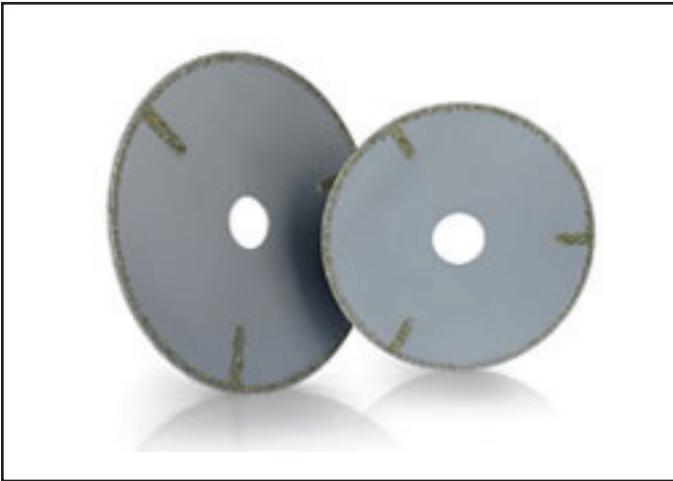

Side-spoked blade

Side-spoked blades are recommended for thicker material or slightly curved cutting. Will prevent saw from jamming in the cut.

Width of diamond coating: 1/8"

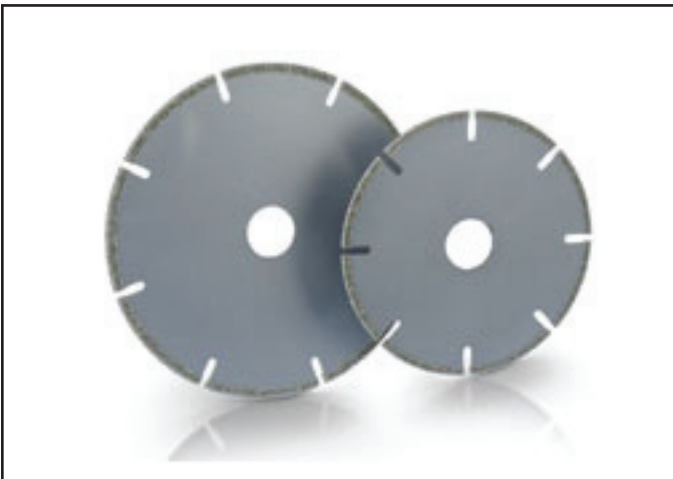

Gulletted blade

Gulletted blades are recommended for material over 3/4" thick.

Width of diamond coating: 1/8".

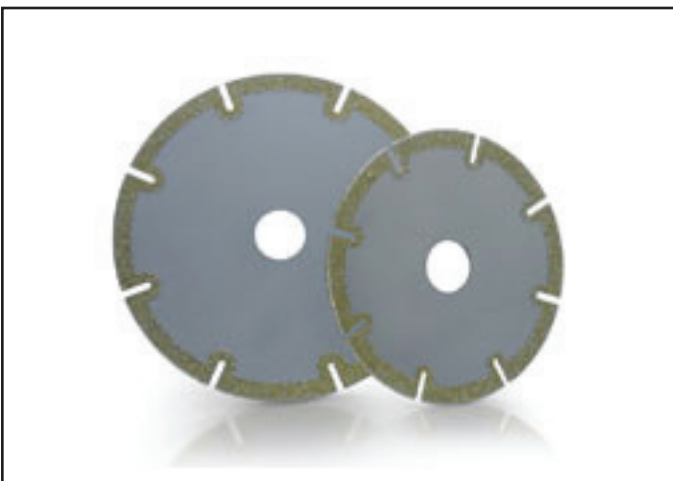

Superspeed 1 blade

Superspeed 1 blades have been designed to include the benefits of our side spoked and our gulletted blades.

BLADES - Continued

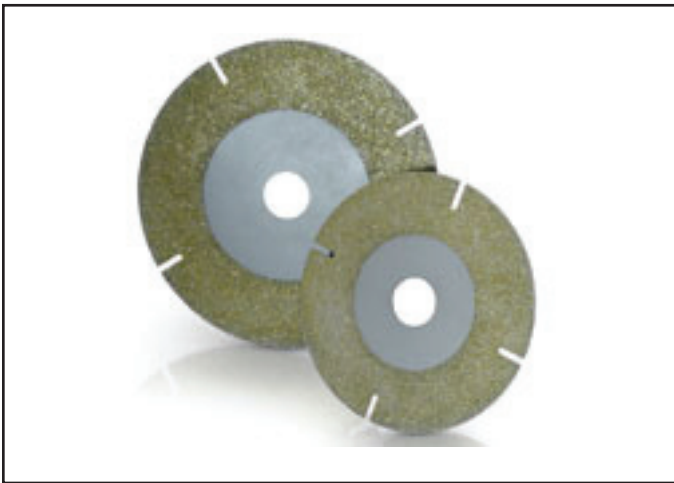

Superspeed 2 blade

Superspeed 2 blades have all the benefits of superspeed 1 plus allow the operator to sand parts without changing tools.



Integral spindle

These saws are used where it is necessary to cut close into a corner. The blade and spindle are made in one piece and present an absolutely flush side to the work. One side of blade has three side spokes to prevent binding in the cut. Special shank sizes available upon request.

TECHNICAL SPECIFICATIONS - BLADES

Diameter	Thickness	Arbor size	Code				
			Continuous rim	Side spoked	Gulleted	Superspeed Model 1	Model 2
1 1/2"	1 / 16"	1 / 4"	50-112116	51-112116	52-112116		
2"	1 / 16"	1 / 4"	50-2116	51-2116	52-2116		
2"	3 / 32"	1 / 4"	50-2332	51-2332	52-2332		
2 1/2"	1 / 16"	1 / 2"	50-212116	51-212116	52-212116		
2 1/2"	3 / 32"	1 / 2"	50-212332	51-212332	52-212332		
3"	1 / 16"	1 / 2"	50-3116	51-3116	52-3116		
3"	3 / 32"	1 / 2"	50-3332	51-3332	52-3332		
4"	1 / 16"	5 / 8"	50-41165	51-41165	52-41165		
4"	1 / 16"	3 / 4"	50-4116	51-4116	52-4116	54-4116	52-4116-1
4"	3 / 32"	3 / 4"	50-4332	51-4332	52-4332	54-4332	52-4332-1
5"	1 / 16"	3 / 4"	50-5116	51-5116	52-5116		52-5116-1
5"	3 / 32"	3 / 4"	50-5332	51-5332	52-5332	54-5332	52-5332-1
6"	3 / 32"	3 / 4"	50-6332	51-6332	52-6332	54-6332	
7"	3 / 32"	5 / 8"	50-7332	51-7332	52-7332		
8"	3 / 32"	5 / 8"	50-8332	51-8332	52-8332		
8"	1 / 8"	5 / 8"	50-818	51-818	52-818		
8"	1 / 8"	7 / 8"				54-81878	
10"	3 / 32"	As required	50-10332	51-10332	52-10332		
10"	1 / 8"	As required	50-1018	51-1018	52-1018		
10"	1 / 8"	7 / 8"				54-101878	
10"	5 / 32"	As required	50-10532	51-10532	52-10532		
12"	1 / 8"	As required	50-1218	51-1218	52-1218		
14"	1 / 8"	As required	50-1418	51-1418	52-1418		
14"	5 / 32"	As required	50-14532	51-14532	52-14532		
16"	5 / 32"	As required	50-16532	51-16532	52-16532		

Special sizes available upon request

Code	Blade diameter	Shank	
		Diameter	Length
53-1	1"	1 / 4"	2"
53-112	1 1/2"	1 / 4"	2"
53-2	2"	1 / 4"	2"
53-238	2"	3 / 8"	3"
53-212	2 1/2"	1 / 4"	2"
53-338	3"	3 / 8"	3"
53-312	3"	1 / 2"	3"

Special sizes available upon request

HOLESAWS



Holesaws

Our holesaws have a corrugated edge which provides extra cutting clearance for speed of drilling and also good core ejection. These holesaws are used with a standard 1/4" pilot drill (not included). An optional ejector spring is available. Special size holesaws available upon request.



Auto-ejection

Auto ejection holesaw will automatically eject FRP cores as quickly as holes are drilled. This unique holesaw was designed for use in a fixture for production drilling.

Prices upon request.

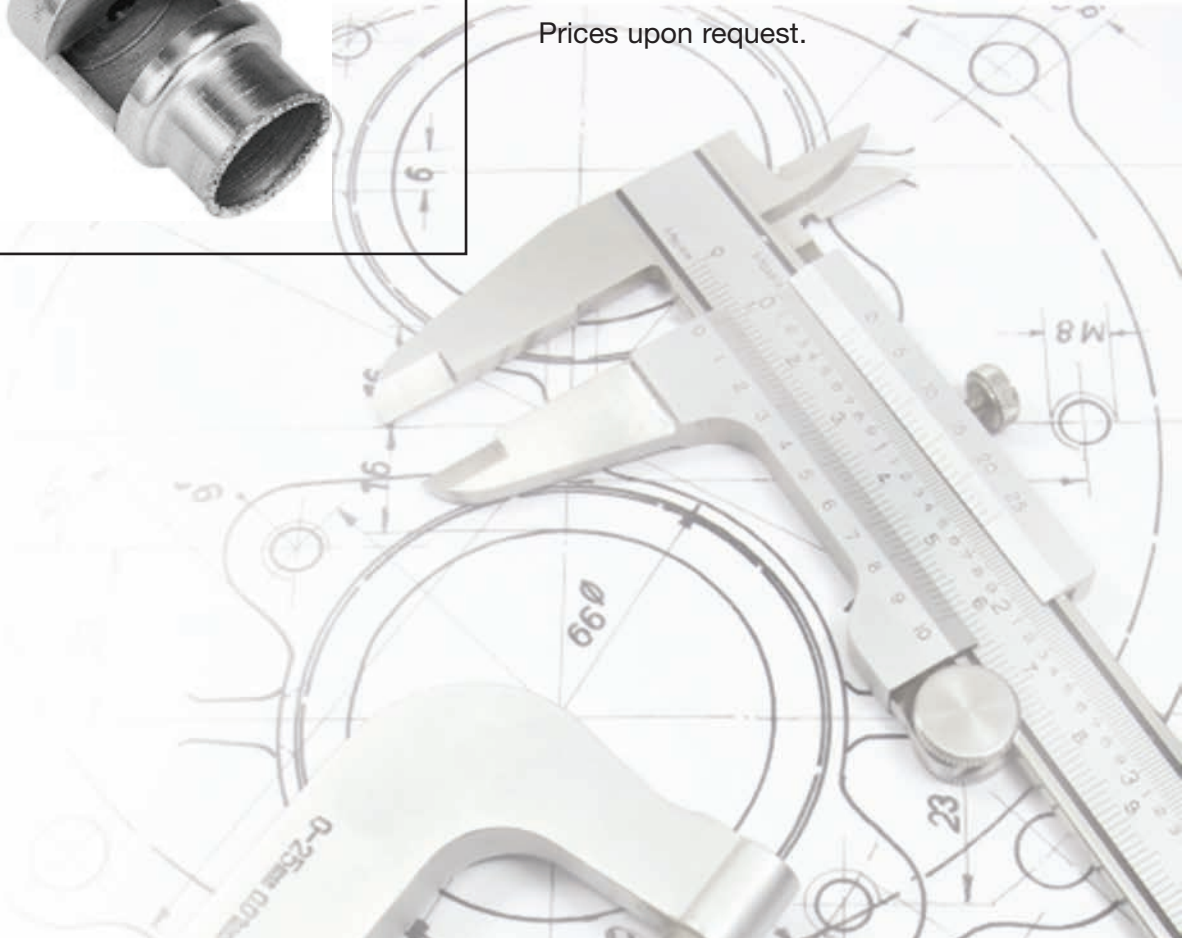

HOLESAWS - Continued



Arbors

Holesaw arbors and spring. Refer to table for appropriate sizes.

TECHNICAL SPECIFICATIONS - HOLESAWS

Code	Diameter		Code	Diameter		Code	Diameter	
	Inches	MM		Inches	MM		Inches	MM
60-0916	9/16"	14	60-158	1 5/8"	41	60-318	3 1/8"	79
60-058	5/8"	16	60-11116	1 11/16"	43	60-314	3 1/4"	83
60-01116	11/16"	17	60-134	1 3/4"	44	60-338	3 3/8"	86
60-034	3/4"	19	60-11316	1 13/16"	46	60-312	3 1/2"	89
60-01316	13/16"	21	60-178	1 7/8"	48	60-358	3 5/8"	92
60-078	7/8"	22	60-2	2"	51	60-334	3 3/4"	95
60-01516	15/16"	24	60-2116	2 1/16"	52	60-378	3 7/8"	98
60-1	1"	25	60-218	2 1/8"	54	60-4	4	102
60-1116	1 1/16"	27	60-214	2 1/4"	57	60-418	4 1/8"	105
60-118	1 1/8"	29	60-2516	2 5/16"	59	60-414	4 1/4"	108
60-1316	1 3/16"	30	60-238	2 3/8"	60	60-438	4 3/8"	111
60-114	1 1/4"	32	60-212	2 1/2"	64	60-412	4 1/2"	114
60-1516	1 5/16"	33	60-2916	2 9/16"	65	60-434	4 3/4"	121
60-138	1 3/8"	35	60-258	2 5/8"	67	60-5	5	127
60-1716	1 7/16"	37	60-234	2 3/4"	70	60-512	5 1/2"	140
60-112	1 1/2"	38	60-278	2 7/8"	73	60-6	6"	152
60-1916	1 9/16"	40	60-3	3"	76			

Special sizes available upon request

Code	Arbors used by these holesaws	Chuck size
67-1	9/16" to 1 3/16"	3 / 8"
67-2	1 1/4" to 6"	1 / 2"
67-3	1 1/4" to 6"	3 / 4"
67-7	Spring	

SPECIAL CUTTERS



Router bits

Router bits are available in several standard sizes. Refer to table to get exact dimensions.

TECHNICAL SPECIFICATIONS - ROUTER BITS

Code	Diamond coating		Overall length	Shank diameter
	Diameter	Length		
85-316	3 / 16"	1 / 2"	2"	1 / 4"
85-14	1 / 4"	1"	2 1/2"	1 / 4"
85-125	3/32" x 3/16"	1"	2 1/2"	1 / 4"
85-516	5 / 16"	1"	2 1/2"	1 / 4"

Special sizes available upon request



Backfacing cutters

Cutters for 20-BF15 backfacer.

TECHNICAL SPECIFICATIONS - BACKFACING CUTTERS

Code	Diameter	Width of cut
70-BF112	1 1/2"	5 / 16"
70-BF2	2"	9 / 16"
70-BF212	2 1/2"	13 / 16"
70-BF3	3"	1 1/16"
70-BF4	4"	1 9/16"

Special sizes available upon request



Surface planing tools

Cutters used for surfacing / planing flat surfaces. For use on drill press or milling machine.

TECHNICAL SPECIFICATIONS - SURFACE PLANING TOOLS

Code	Cutter diameter	Spindle size
75-112	1 1/2"	As required
75-2	2"	As required
75-212	2 1/2"	As required
75-3	3"	As required

Special sizes available upon request

SPECIAL CUTTERS - Continued

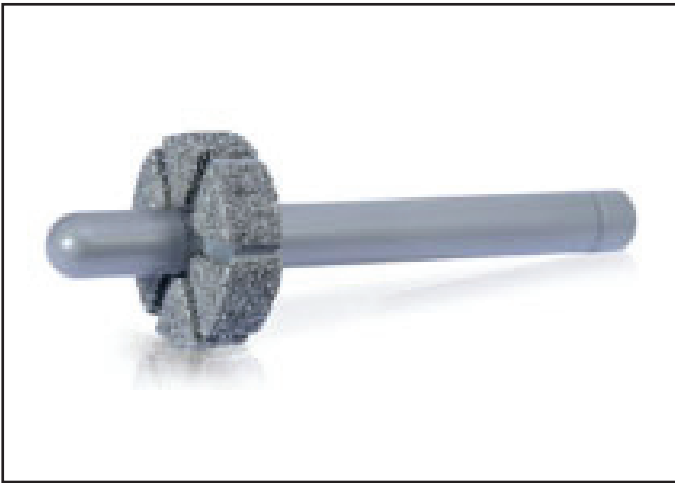

Counterbores

To counterbore holes in pipe flanges, bathtubs etc. May be used in portable drill.

TECHNICAL SPECIFICATIONS - COUNTERBORES

Code	Cutter diameter	Spindle size	Pilot diameter
80-112	1 1/2"	As required	As required
80-2	2"	As required	As required
80-212	2 1/2"	As required	As required
80-3	3"	As required	As required
Special sizes available upon request			



Backfacing routers

Routers for 20-BF10 backfacer.

TECHNICAL SPECIFICATIONS - BACKFACING ROUTERS

Code	Width of cut
70-2232	1 1/4"
70-2238	1 1/2"
70-2250	2"
70-2265	2 1/2"
Special sizes available upon request	

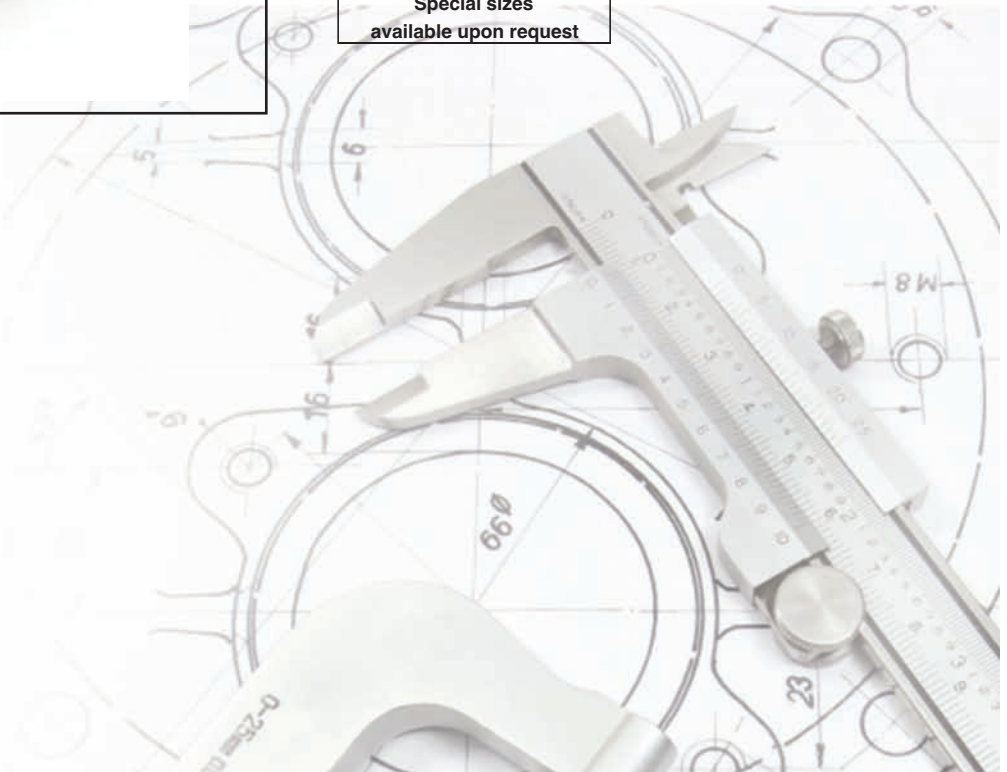

WARRANTY

Pneumatic tools

All our pneumatic tools, except for the SE 50 high speed router, are guaranteed for one year from date of purchase. Our SE 50 high speed router is guaranteed for 90 days. If there is any flaw in workmanship or material detected during this time, we will promptly repair or replace the tool at no charge¹, as long as this defect is not the result of mishandling or abuse.

Diamond products

All Diatrim diamond coated products are guaranteed against diamond peeling. If peeling should occur, products will be replaced free of charge when returned to Diatrim¹.

1. Shipping and customs fees must be paid by the client.

PROCEDURE TO RETURN PRODUCTS

1) Contact our customer service department to get a return authorization number. No product will be accepted without this return authorization number. Returns must be pre-authorized.

2) Write the return authorization number on all documentations and also on the shipping package.

3) Ship the product to Diatrim:

Diatrim
2830 de Miniac
Montreal, Quebec, Canada
H4S 1K9

TERMS AND CONDITIONS

Accepted payment methods: checks, VISA, cash and wire transfers.

Upon opening a business account, terms of 2% / 10 days, net 30 days. Subject to a credit limit.

Procedures to order:

Fax: 514-336-1344

Email: info@diatrim.com

Phone: 1-888-336-4893

All products delivered remain the property of Diatrim until fully paid.

Fees of 1,5% per month (18% per year) will be charged on all past due accounts.

No returns on customized special tools.

Any claim regarding shipments or invoices must be made within 10 days of reception.

Prices are subject to changes without notice.

Freight will be prepaid for items that are back orders.



ORDER AND INFORMATION

DIATRIM TOOLS LTD
2830 DE MINIAC
MONTREAL, QUEBEC, CANADA H4S 1K9

TOLL FREE: 1-888-336-4893
TEL.: (514) 336-7280
FAX.: (514) 336-1344
info@diatrim.com

www.diatrim.com