



Pneumatic Riveter

R1A1
R1A2

MADE IN JAPAN tradition

Pneumatic Riveter

R1A1

R1A2

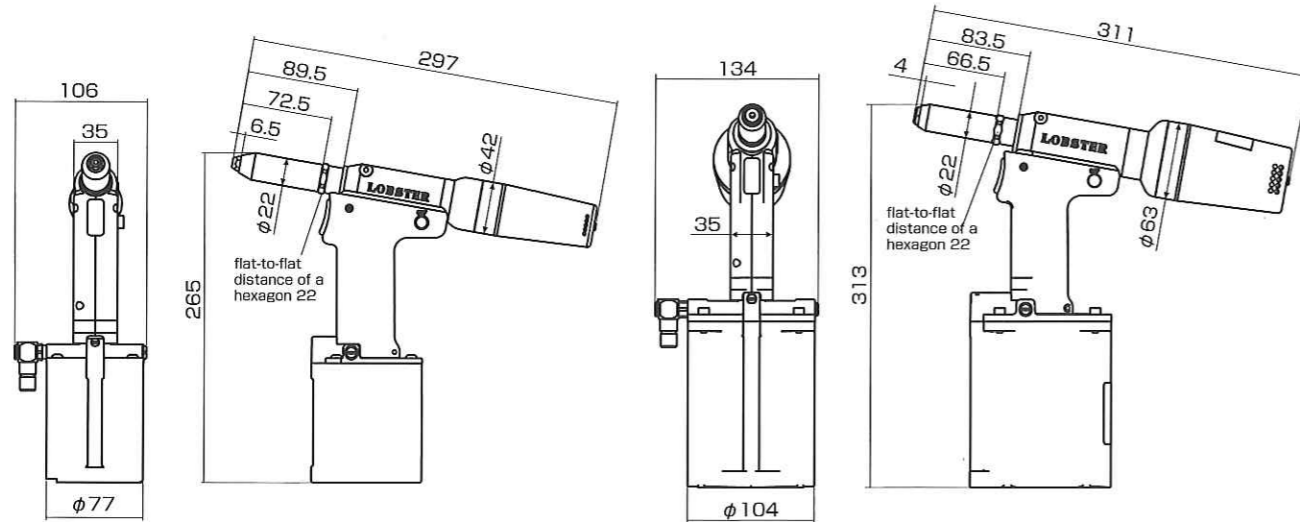

Model	Weight kg (lbs)	Compatible Rivets φmm (inch)	Jaw	Used air pressure MPa (kgf/cm ²)	Traction Power kN (lb.f)	Stroke mm (inch)	Air Consumption L/min	Noise Emission dB
R1A1	1.1 (2.43)	all material 2.4 / 3.2 / 4.0 / 4.8 (3/32", 1/8", 5/32", 3/16")	Ultra Jaw 'M'	0.49~0.59 (5~6)	10.0 (2,248)**	19 (.748")	68** (Vacuum on)	69.5
R1A2	1.74 (3.84)	all material 4.8 / 6.4 (3/16", 1/4")	Ultra Jaw 'L'	0.49~0.59 (5~6)	18.5 (4,158)**	26 (1.02")	75** (Vacuum on)	80

**Air pressure at 0.59 Mpa

⚠ Caution for secure usage Be sure to read the enclosed Instruction Manual carefully and make sure that you understand them thoroughly before using this tool.

- All dimensions are nominal and subject to tolerances.
- Specifications are subject to change without prior notice.

LOBSTER LOBTEX CO.,LTD.

International Marketing Group
TEL+81(72)981-7466 FAX+81(72)981-9420
12-8 Shijo-Cho,Higashi-Osaka City,Osaka 579-8053 Japan
URL : www.riveter.com www.lobtex.co.jp/

No.16Y-2000TO-3

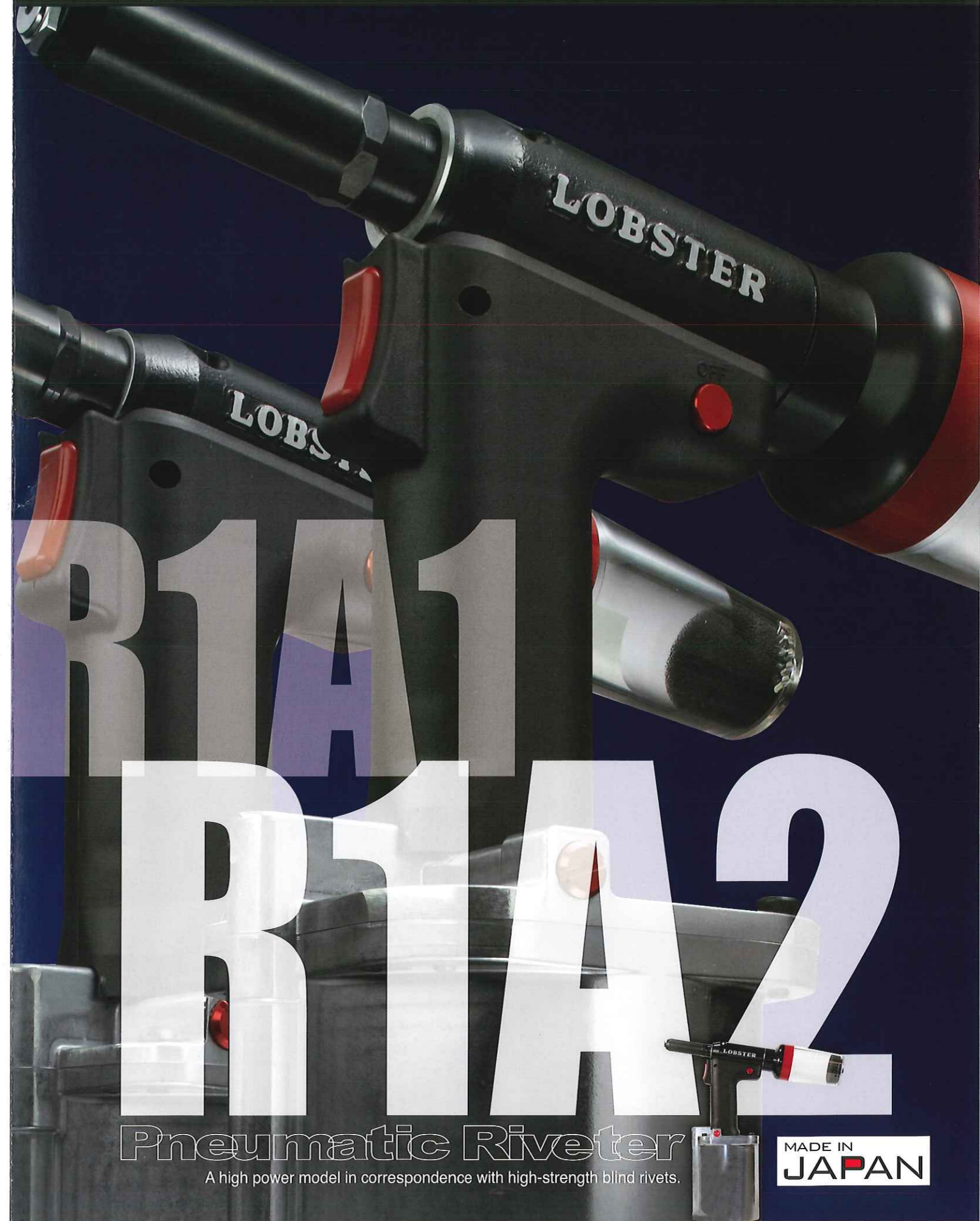

Pneumatic Riveter

A high power model in correspondence with high-strength blind rivets.

MADE IN JAPAN